

ADVERTISEMENT
CONY BROCHURE

Zhengzhou Known Imp.& Exp.Co., Ltd.
郑州诺恩进出口有限公司

Mobile:+86-180 3730 6386

Email :info@knownmachine.com

Web:http://www.foodtruckfactory.cn/

Add:Room 1402,14th Floor,Building 3,No.131,Jianye Road,Jinshui
District,Zhengzhou City,Henan Provice,China



ZHENGZHOU KNOWN IMP.&EXP.CO.,LTD.

One-stop service concept, from design,
production to delivery,You only need to
provide your ideas and we will help you
customize a complete programme that
suits you

**PRODUCT
CATALOG**



TOILET TRAILER

ABOUT US



Zhengzhou Known Imp. & Exp. Co., Ltd., established in March 2011, as one professional manufacturer engaged in the Research, Development, Production, Sale and Service of Trailer, Truck, Tricycle, **Toilet Trailer**, Container Bar, Food Kiosk, Ice Cream Cart, and other related other devices .

Dedicated to strict quality control and thoughtful customer service, our experienced staff members are always available to discuss your requirements and welcome O E M and O D M orders, whether selecting a current product from our catalog or seeking engineering assistance for your application, you can talk to our customer service center about your sourcing requirements, we will provide a full range of one-stop service from providing project proposals & design drawings to customized production, including the relevant equipment! Our factory has advanced equipment, strict quality inspection and fast delivery. Welcome to visit us and establish long terms business relation!



CONTENTS

About Us ————— 01

- Our factory
- Our certification
- Our team
- Customer visit

Toilet Trailer ————— 02

- Recommended style
- Custom case style

More Information ————— 03

- Standard configuration
- Options
- Order process
- Loading and shipment



OUR FACTORY

ZZKNOWN factory own the World Manufacturer Identifier code (WMI), which maintains a high level quality inspection & control, from materials, parts, frame, electric system, water system, fire-resistant, water-proof, inside, kitchen equipment layout & installation, polishing, spraying painting, packing and , shipping. Creating strong, long-lasting, attractive containers represent our basic principle. Through continual top quality, innovation and great service, we are , favored by more and more global customers every day. We will do all efforts to realize your dream!



OUR CERTIFICATION

①

We sincerely welcome customers from home and abroad to visit us for cooperation. We believe our company will be your most reliable partner and friend. Your satisfaction is our greatest pursuit. I committed to providing customers with the best products

②

Our factory own the World Manufacturer Identifier code (WMI). For the market of North American, we have completed registration with United States Department of Transportation with DOT and VIN number; For the market of Europe, our products has passed the CE certification and other related certifications. Our products selling well in all cities and provinces around China, and always exported to the United States, Canada, Australia, New Zealand, Italy, Spain, France, Arabia, United Arab Emirates, Chile and other countries.





OUR TEAM

We have a professional technical, sales and service team, 7*24hours online to provide service for you! We will provide a full range of one-stop service from providing project proposals & design drawings to customized production, including the relevant equipment!



CUSTOMER VISIT



TOILET TRAILER



KN-220CS	
Body Size (L*W*H)	2200*2100*2550mm (7.21'x6.89'x8.36' ft)
Weight(kg)	850kg
Layout	2 Toilets + 1 Mechanical room
Package	40HQ container will fit in 5 units
MOQ	1 unit

Main Advantage:

1. Mobile public toilets have the advantages of being mobile, combined, and convenient for transportation.
2. Water saving: it saves 10 times as much water as the traditional flushing toilet, and the water consumption for each time is $\leq 0.5L$.
3. Energy saving: reduce sewage discharge, reduce the load of municipal sewage treatment plants by 80%, and save energy consumption.
4. Fresh air: when the excrement is sucked away, about 60 liters of air around the foreign body is sucked away, and the air is fresh and has no peculiar smell.
5. Stable performance: Adopt foreign imported accessories, and independently develop and integrate PLC control system, which is intelligent, stable, and simple to maintain.

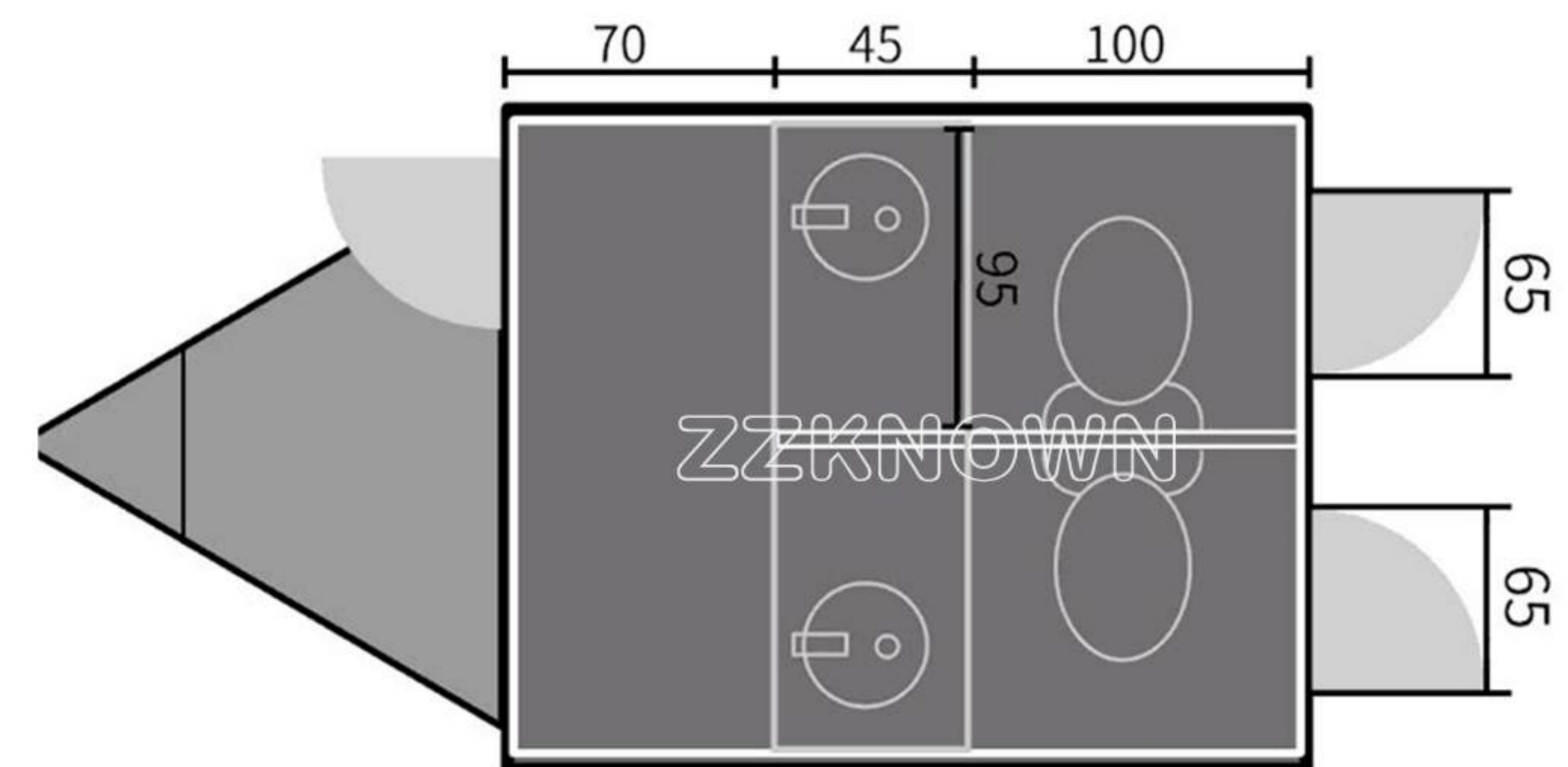

(No matter the length or the internal layout, it all can be customized!)

TOILET TRAILER



KN-350CS-1

Body Size (L*W*H)	3500*2100*2550mm (11.48'x6.89'x8.36' ft)
Weight(kg)	1000kg
Layout	4 Toilets + 1 Mechanical room
Package	40HQ container will fit in 3 units
MOQ	1 unit

Main Advantage:

1. Mobile public toilets have the advantages of being mobile, combined, and convenient for transportation.
2. Water saving: it saves 10 times as much water as the traditional flushing toilet, and the water consumption for each time is $\leq 0.5L$.
3. Energy saving: reduce sewage discharge, reduce the load of municipal sewage treatment plants by 80%, and save energy consumption.
4. Fresh air: when the excrement is sucked away, about 60 liters of air around the foreign body is sucked away, and the air is fresh and has no peculiar smell.
5. Stable performance: Adopt foreign imported accessories, and independently develop and integrate PLC control system, which is intelligent, stable, and simple to maintain.

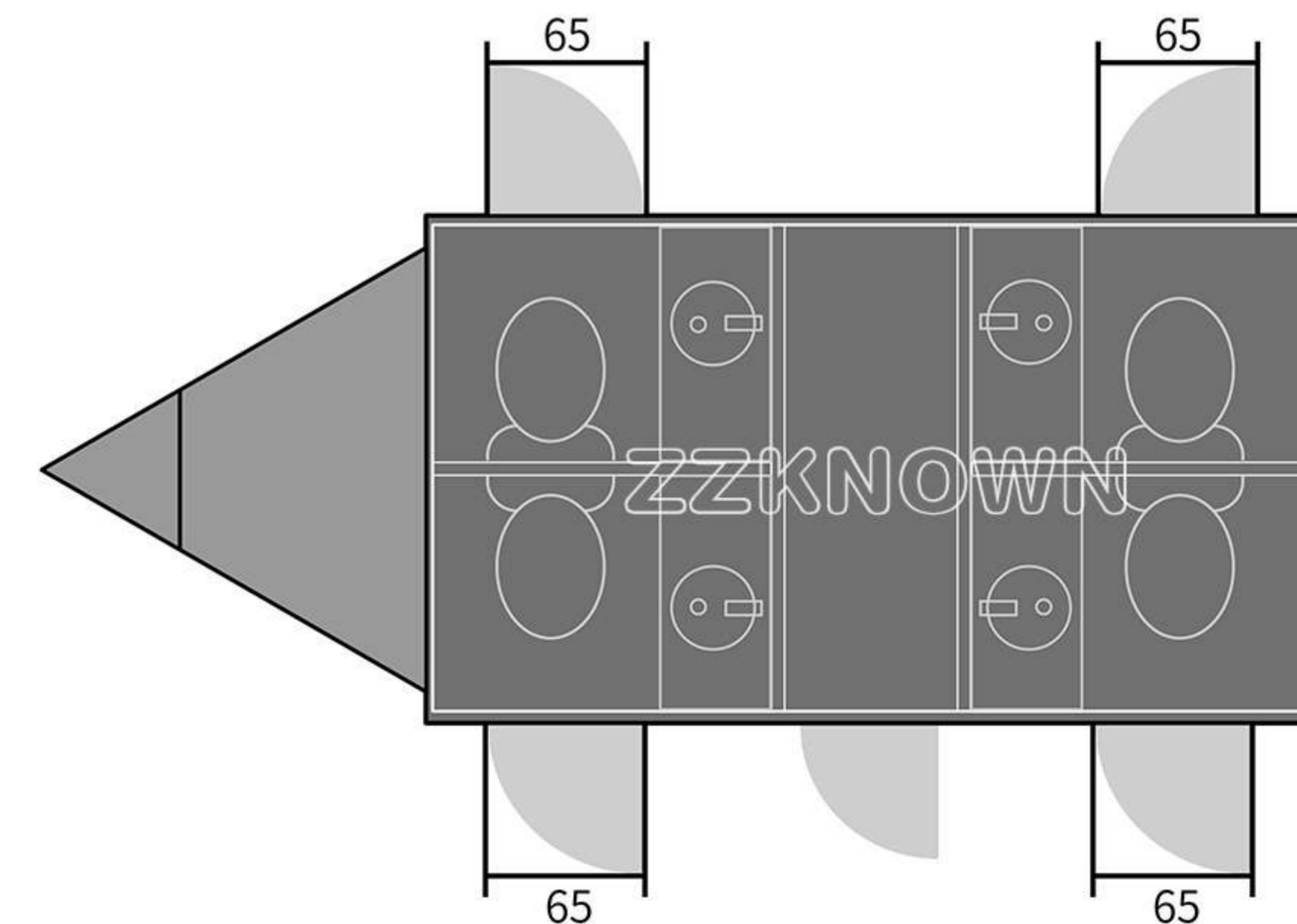

(No matter the length or the internal layout, it all can be customized!)

TOILET TRAILER



KN-360CS-1

Body Size (L*W*H)	3600*1700*2550mm (11.81'x5.57'x8.36' ft)
Weight(kg)	1000kg
Layout	2Toilets & 2 urinal + 1 Mechanical room
Package	40HQ container will fit in 3 units
MOQ	1 unit

Main Advantage:

1. Mobile public toilets have the advantages of being mobile, combined, and convenient for transportation.
2. Water saving: it saves 10 times as much water as the traditional flushing toilet, and the water consumption for each time is $\leq 0.5L$.
3. Energy saving: reduce sewage discharge, reduce the load of municipal sewage treatment plants by 80%, and save energy consumption.
4. Fresh air: when the excrement is sucked away, about 60 liters of air around the foreign body is sucked away, and the air is fresh and has no peculiar smell.
5. Stable performance: Adopt foreign imported accessories, and independently develop and integrate PLC control system, which is intelligent, stable, and simple to maintain.

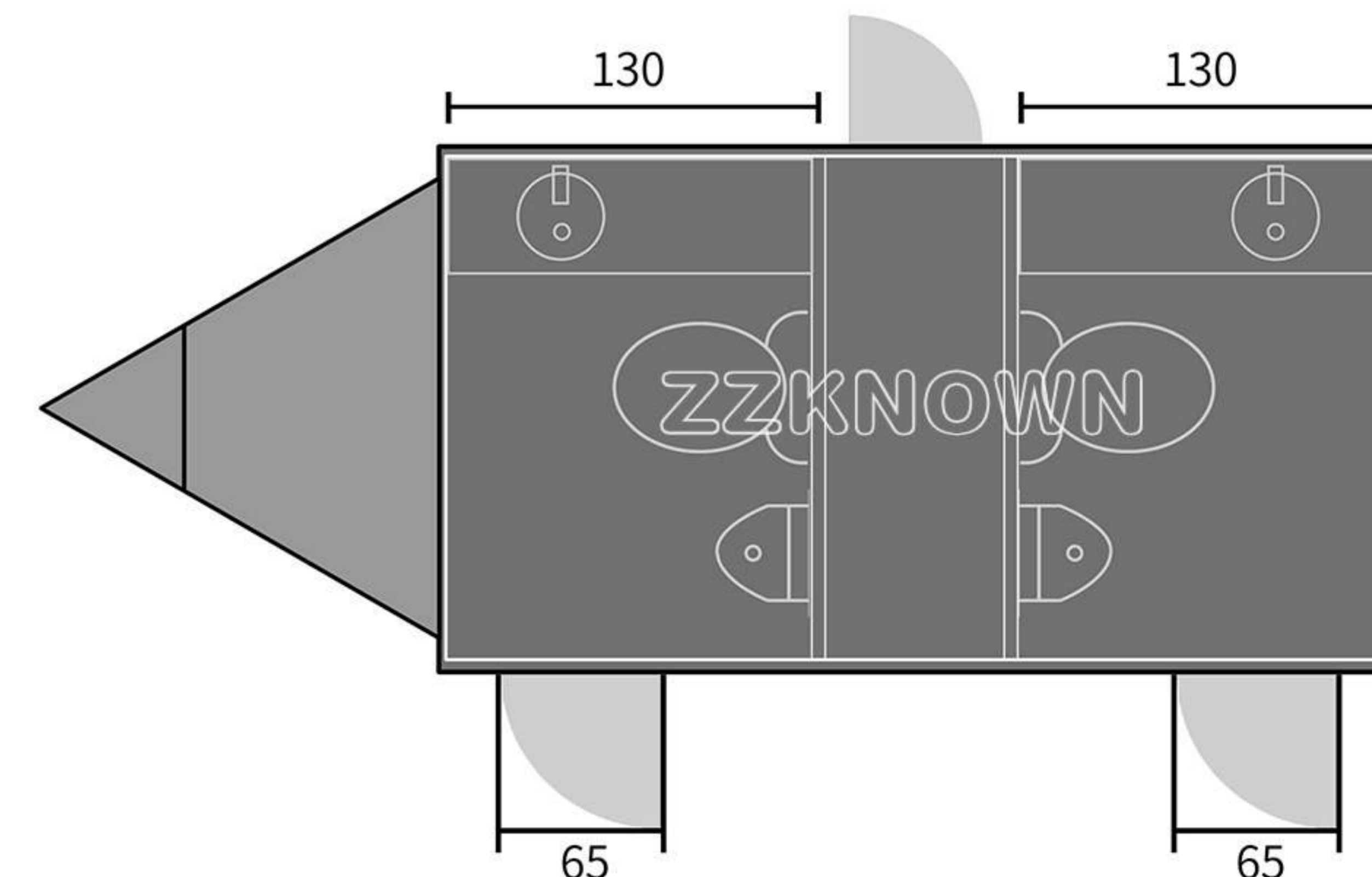

(No matter the length or the internal layout, it all can be customized!)

TOILET TRAILER



KN-430CS

Body Size (L*W*H)	4300*2100*2550mm (14.1'x6.89'x8.36' ft)
Weight(kg)	1300kg
Layout	4 Toilets + 1 Mechanical room
Package	40HQ container will fit in 2 units
MOQ	1 unit

Main Advantage:

1. Mobile public toilets have the advantages of being mobile, combined, and convenient for transportation.
2. Water saving: it saves 10 times as much water as the traditional flushing toilet, and the water consumption for each time is $\leq 0.5L$.
3. Energy saving: reduce sewage discharge, reduce the load of municipal sewage treatment plants by 80%, and save energy consumption.
4. Fresh air: when the excrement is sucked away, about 60 liters of air around the foreign body is sucked away, and the air is fresh and has no peculiar smell.
5. Stable performance: Adopt foreign imported accessories, and independently develop and integrate PLC control system, which is intelligent, stable, and simple to maintain.

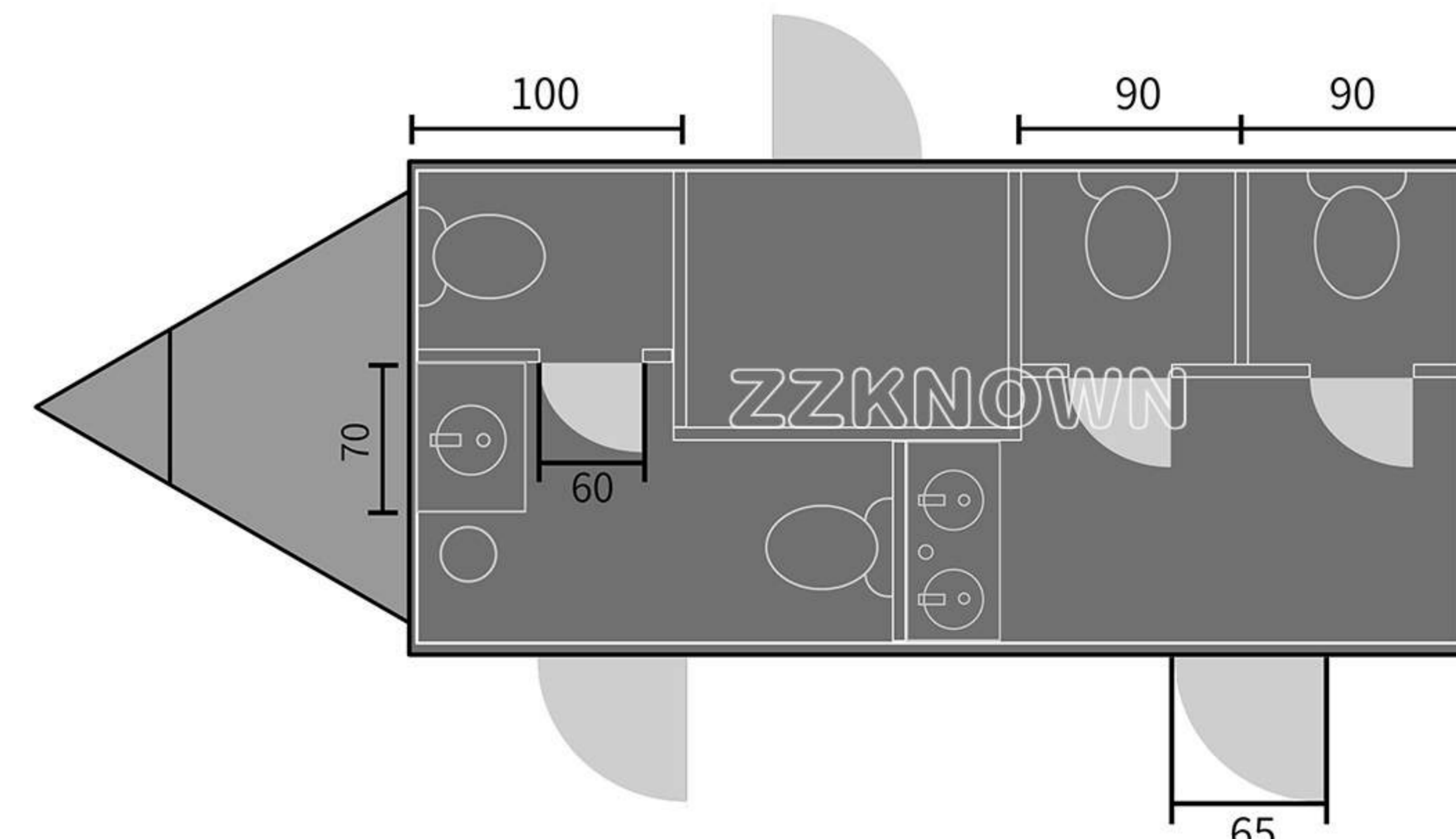

(No matter the length or the internal layout, it all can be customized!)

TOILET TRAILER



KN-580CS	
Body Size (L*W*H)	5800*2100*2550mm (19'x6.89'x8.36' ft)
Weight(kg)	1500kg
Layout	5 Toilets & 2 urinal + 1 Mechanical room
Package	40HQ container will fit in 2 units
MOQ	1 unit

Main Advantage:

1. Mobile public toilets have the advantages of being mobile, combined, and convenient for transportation.
2. Water saving: it saves 10 times as much water as the traditional flushing toilet, and the water consumption for each time is $\leq 0.5L$.
3. Energy saving: reduce sewage discharge, reduce the load of municipal sewage treatment plants by 80%, and save energy consumption.
4. Fresh air: when the excrement is sucked away, about 60 liters of air around the foreign body is sucked away, and the air is fresh and has no peculiar smell.
5. Stable performance: Adopt foreign imported accessories, and independently develop and integrate PLC control system, which is intelligent, stable, and simple to maintain.

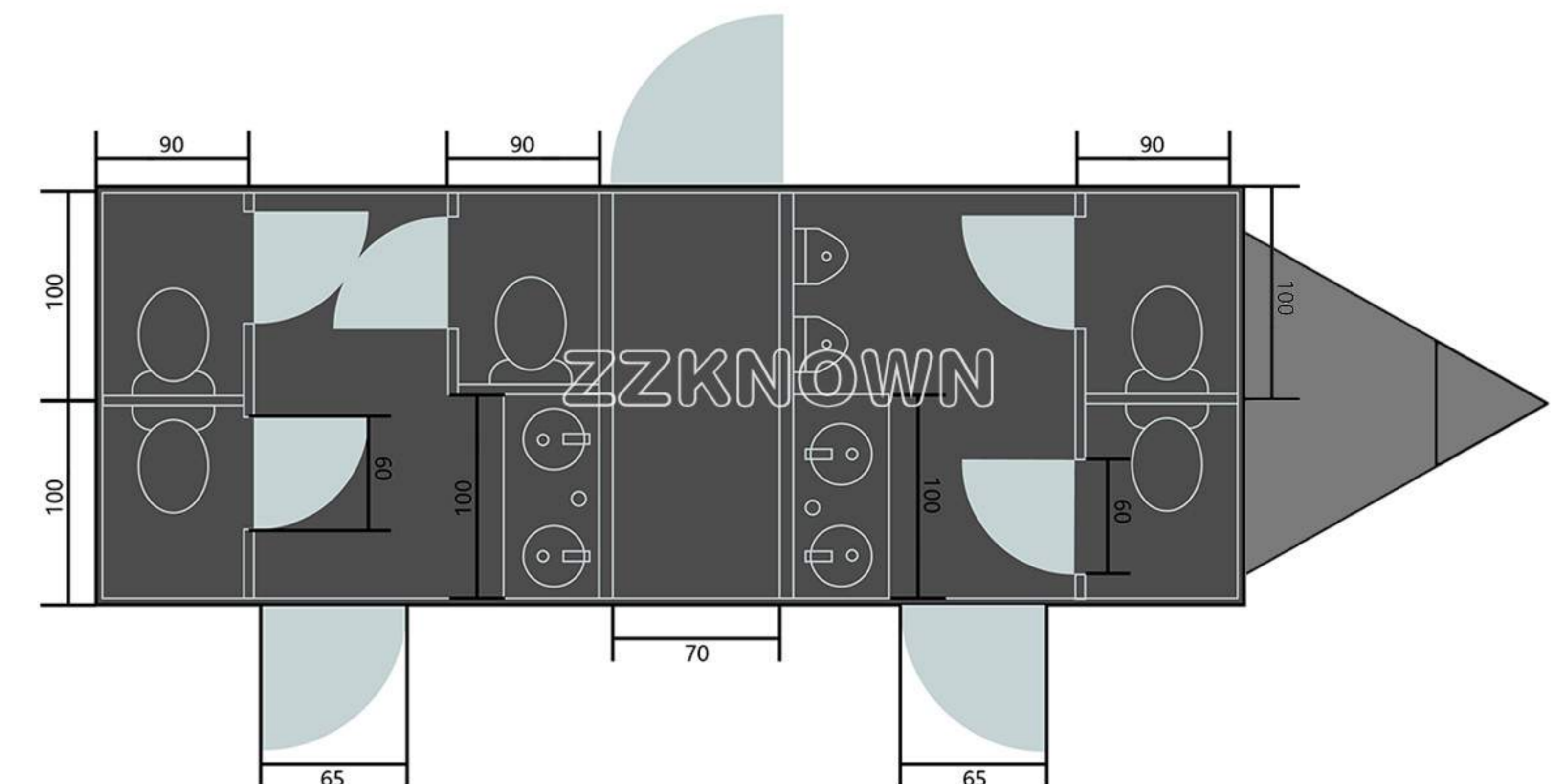

(No matter the length or the internal layout, it all can be customized!)

TOILET TRAILER



KN-290CS-1

Body Size (L*W*H)	2900*1800*2550mm (9.51'x5.91'x8.36' ft)
Weight(kg)	900kg
Layout	2 Toilets & 1 urinal + 1 Mechanical room
Package	40HQ container will fit in 4 units
MOQ	1 unit

Main Advantage:

1. Mobile public toilets have the advantages of being mobile, combined, and convenient for transportation.
2. Water saving: it saves 10 times as much water as the traditional flushing toilet, and the water consumption for each time is $\leq 0.5L$.
3. Energy saving: reduce sewage discharge, reduce the load of municipal sewage treatment plants by 80%, and save energy consumption.
4. Fresh air: when the excrement is sucked away, about 60 liters of air around the foreign body is sucked away, and the air is fresh and has no peculiar smell.
5. Stable performance: Adopt foreign imported accessories, and independently develop and integrate PLC control system, which is intelligent, stable, and simple to maintain.

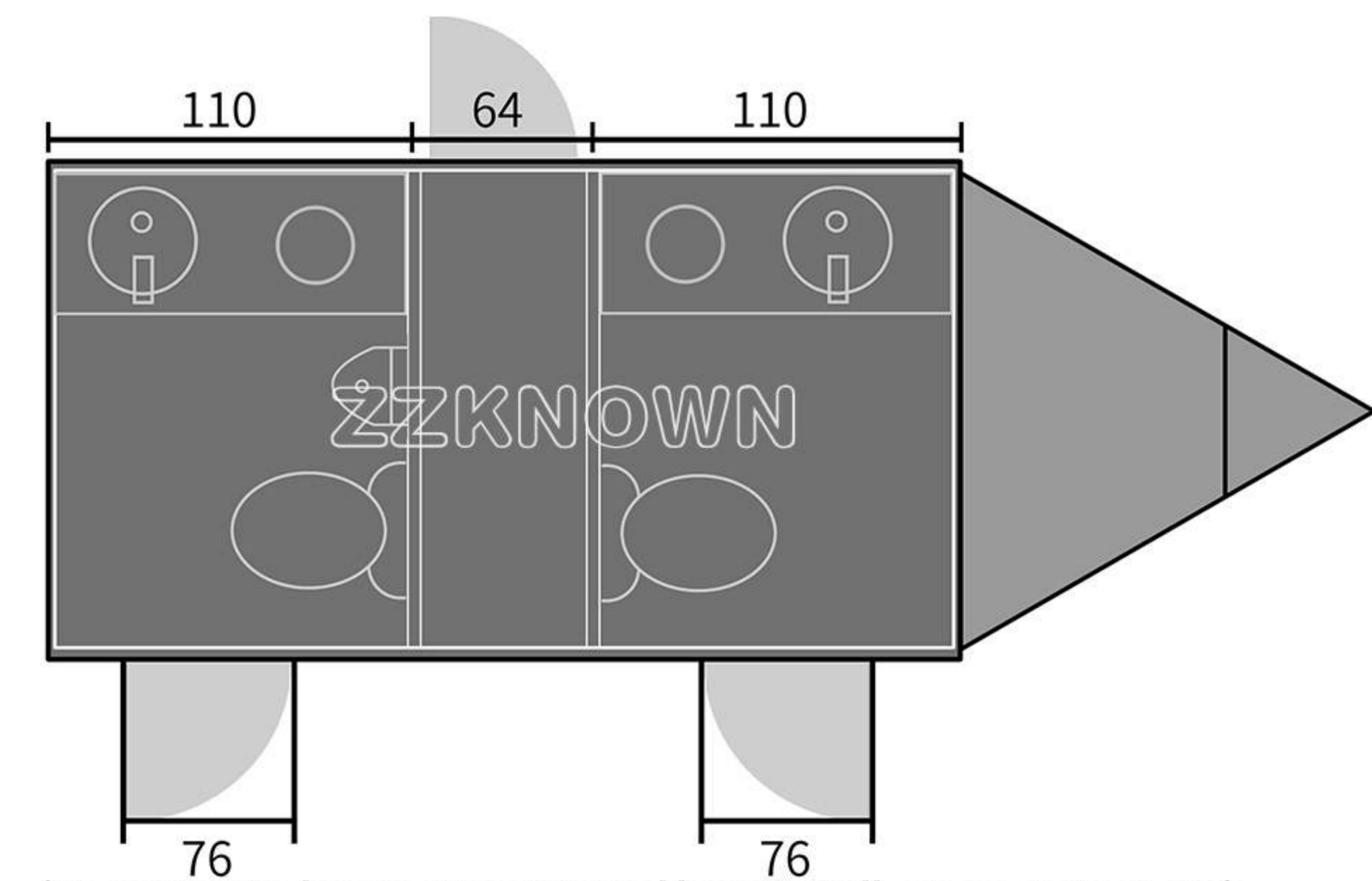

(No matter the length or the internal layout, it all can be customized!)

TOILET TRAILER



KN-290CS-2

Body Size (L*W*H)	2900*1800*2550mm (9.51'x5.91'x8.36' ft)
Weight(kg)	900kg
Layout	2 Toilets & 1 urinal + 1 Mechanical room
Package	40HQ container will fit in 4 units
MOQ	1 unit

Main Advantage:

1. Mobile public toilets have the advantages of being mobile, combined, and convenient for transportation.
2. Water saving: it saves 10 times as much water as the traditional flushing toilet, and the water consumption for each time is $\leq 0.5L$.
3. Energy saving: reduce sewage discharge, reduce the load of municipal sewage treatment plants by 80%, and save energy consumption.
4. Fresh air: when the excrement is sucked away, about 60 liters of air around the foreign body is sucked away, and the air is fresh and has no peculiar smell.
5. Stable performance: Adopt foreign imported accessories, and independently develop and integrate PLC control system, which is intelligent, stable, and simple to maintain.

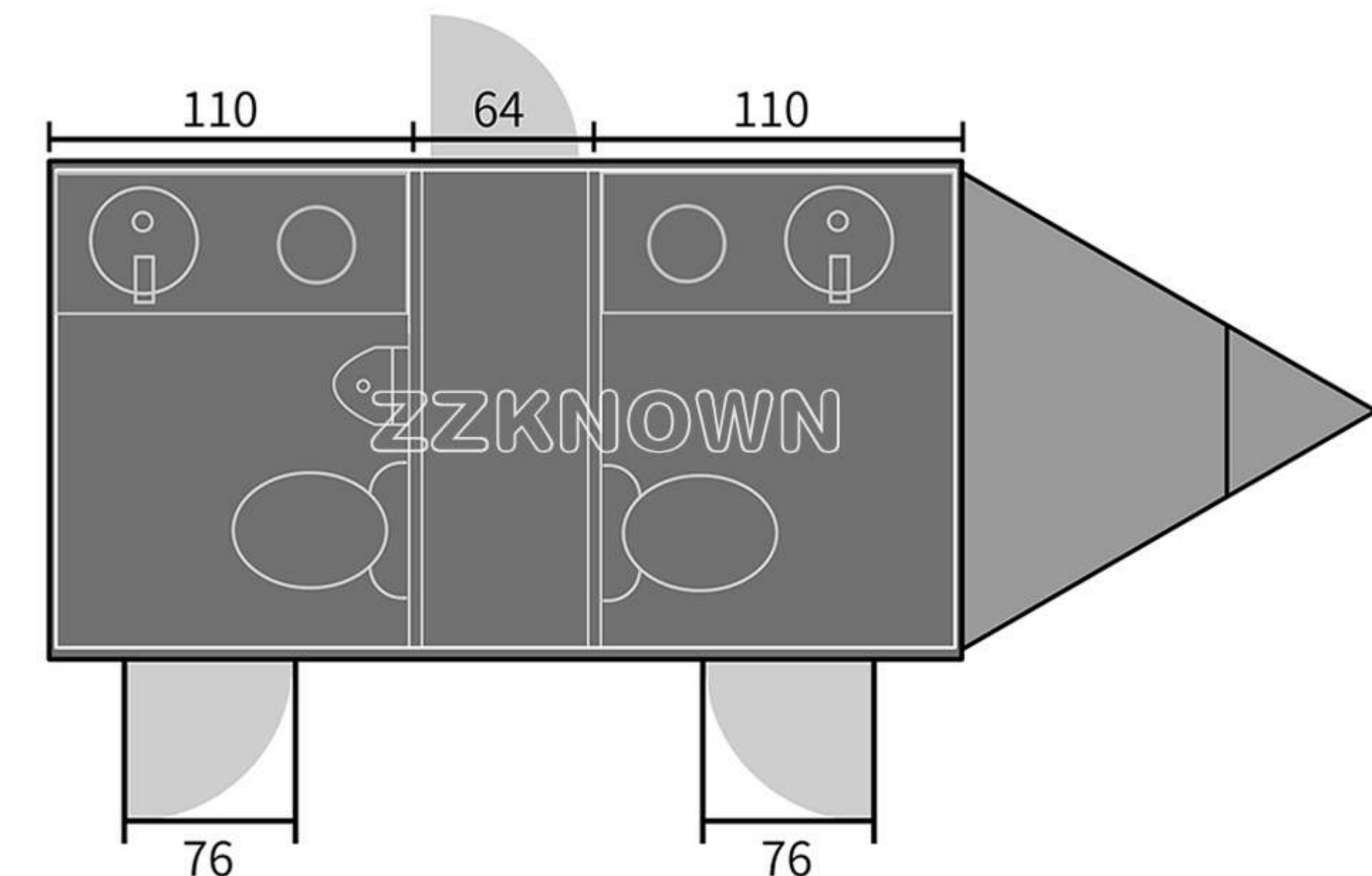

(No matter the length or the internal layout, it all can be customized!)

TOILET TRAILER



KN-350CS-2

Body Size (L*W*H)	3500*1500*2550mm (11.48'x4.92'x8.36' ft)
Weight(kg)	1000kg
Layout	2 Toilets + 1 Mechanical room
Package	40HQ container will fit in 3 units
MOQ	1 unit

Main Advantage:

1. Mobile public toilets have the advantages of being mobile, combined, and convenient for transportation.
2. Water saving: it saves 10 times as much water as the traditional flushing toilet, and the water consumption for each time is $\leq 0.5L$.
3. Energy saving: reduce sewage discharge, reduce the load of municipal sewage treatment plants by 80%, and save energy consumption.
4. Fresh air: when the excrement is sucked away, about 60 liters of air around the foreign body is sucked away, and the air is fresh and has no peculiar smell.
5. Stable performance: Adopt foreign imported accessories, and independently develop and integrate PLC control system, which is intelligent, stable, and simple to maintain.

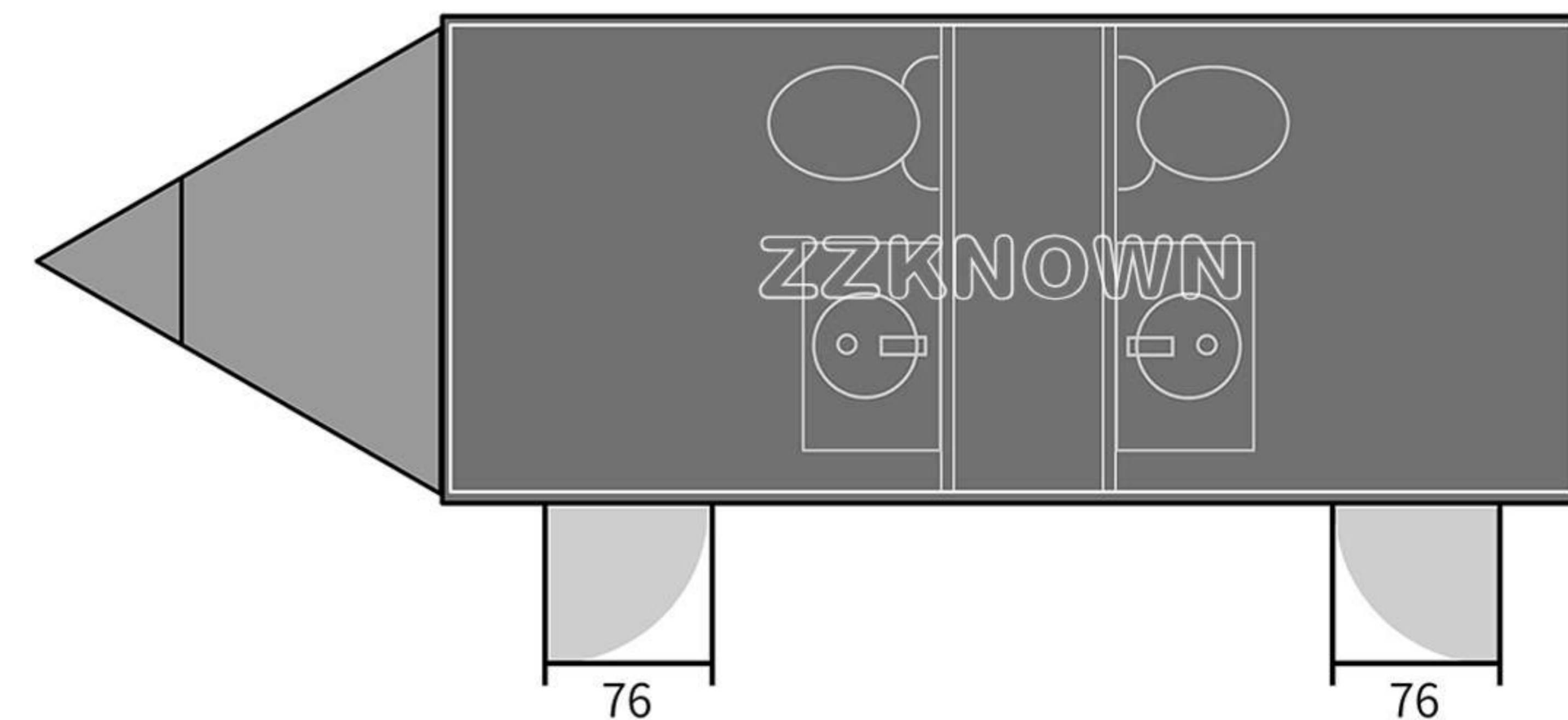

(No matter the length or the internal layout, it all can be customized!)

TOILET TRAILER



KN-360CS-2

Body Size (L*W*H)	3600*2100*2550mm (11.81'x6.89'x8.36' ft)
Weight(kg)	1000kg
Layout	2 Toilets + 1 Mechanical room
Package	40HQ container will fit in 3 units
MOQ	1 unit

Main Advantage:

1. Mobile public toilets have the advantages of being mobile, combined, and convenient for transportation.
2. Water saving: it saves 10 times as much water as the traditional flushing toilet, and the water consumption for each time is $\leq 0.5L$.
3. Energy saving: reduce sewage discharge, reduce the load of municipal sewage treatment plants by 80%, and save energy consumption.
4. Fresh air: when the excrement is sucked away, about 60 liters of air around the foreign body is sucked away, and the air is fresh and has no peculiar smell.
5. Stable performance: Adopt foreign imported accessories, and independently develop and integrate PLC control system, which is intelligent, stable, and simple to maintain.

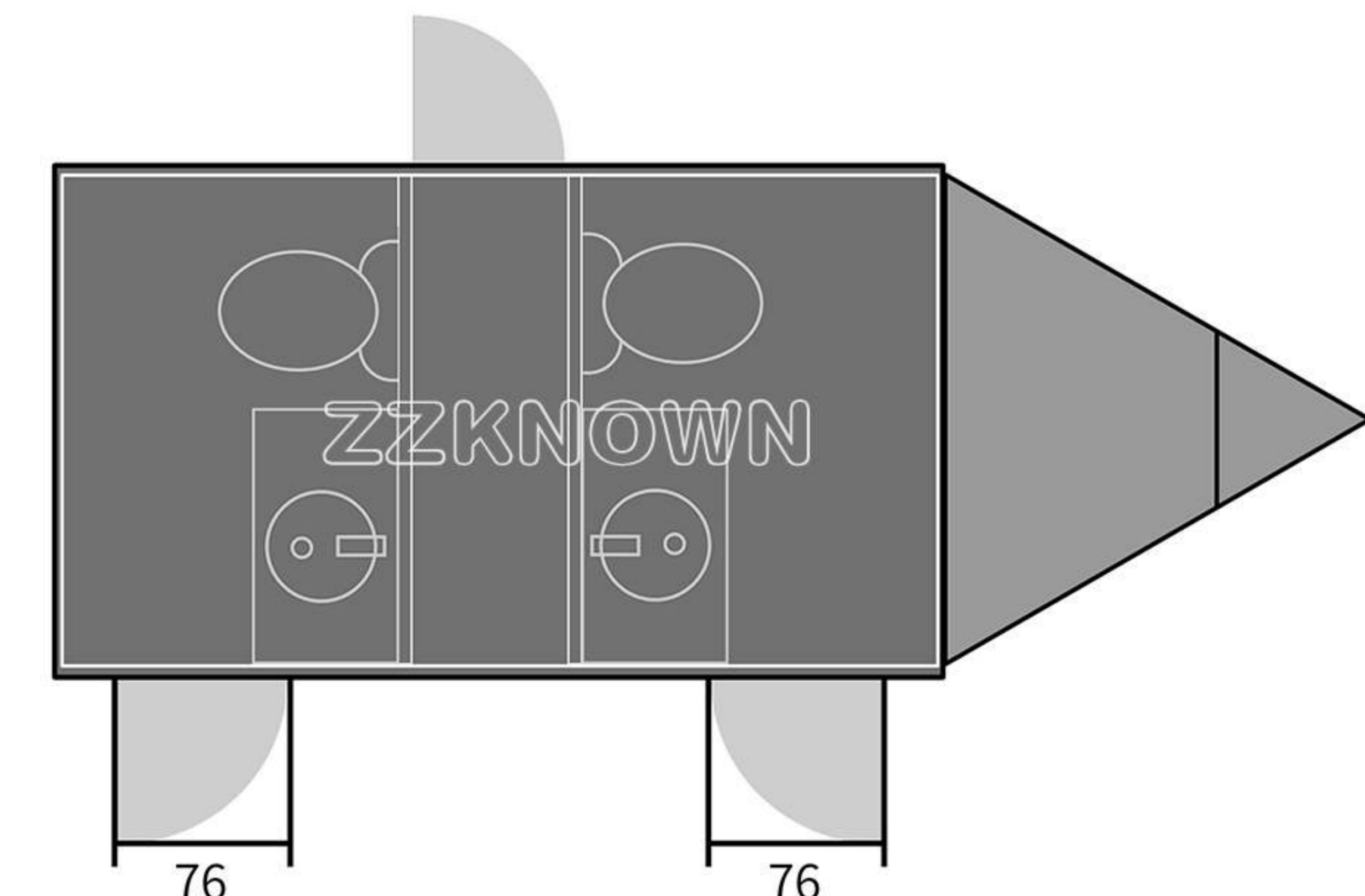

(No matter the length or the internal layout, it all can be customized!)

TOILET TRAILER



KN-420CS

Body Size (L*W*H)	4200*2200*2300mm (13.78'x7.22'x8.36' ft)
Weight(kg)	1300kg
Layout	4 Toilets + 1 Mechanical room
Package	40HQ container will fit in 2 units
MOQ	1 unit

Main Advantage:

- 1.Mobile public toilets have the advantages of being mobile, combined, and convenient for transportation.
- 2.Water saving: it saves 10 times as much water as the traditional flushing toilet, and the water consumption for each time is $\leq 0.5L$.
- 3.Energy saving: reduce sewage discharge, reduce the load of municipal sewage treatment plants by 80%, and save energy consumption.
- 4.Fresh air: when the excrement is sucked away, about 60 liters of air around the foreign body is sucked away, and the air is fresh and has no peculiar smell.
- 5.Stable performance: Adopt foreign imported accessories, and independently develop and integrate PLC control system, which is intelligent, stable, and simple to maintain.

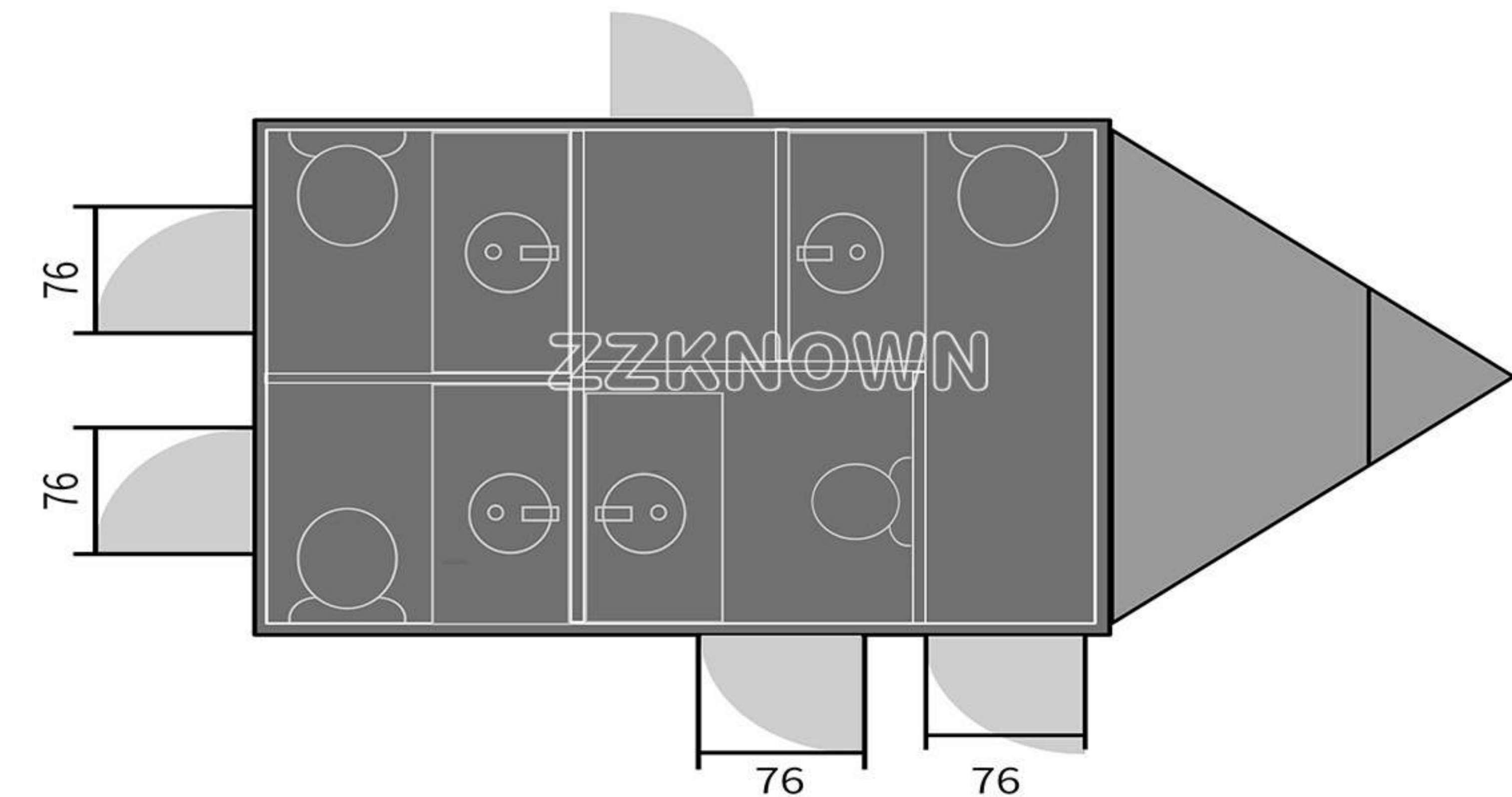

(No matter the length or the internal layout, it all can be customized!)

TOILET TRAILER



KN-480CS	
Body Size (L*W*H)	4800*2100*2550mm (15.75'x6.89'x8.36' ft)
Weight(kg)	1400kg
Layout	3 Toilets & 1 urinal + 1 Mechanical room
Package	40HQ container will fit in 2 units
MOQ	1 unit

Main Advantage:

1. Mobile public toilets have the advantages of being mobile, combined, and convenient for transportation.
2. Water saving: it saves 10 times as much water as the traditional flushing toilet, and the water consumption for each time is $\leq 0.5L$.
3. Energy saving: reduce sewage discharge, reduce the load of municipal sewage treatment plants by 80%, and save energy consumption.
4. Fresh air: when the excrement is sucked away, about 60 liters of air around the foreign body is sucked away, and the air is fresh and has no peculiar smell.
5. Stable performance: Adopt foreign imported accessories, and independently develop and integrate PLC control system, which is intelligent, stable, and simple to maintain.

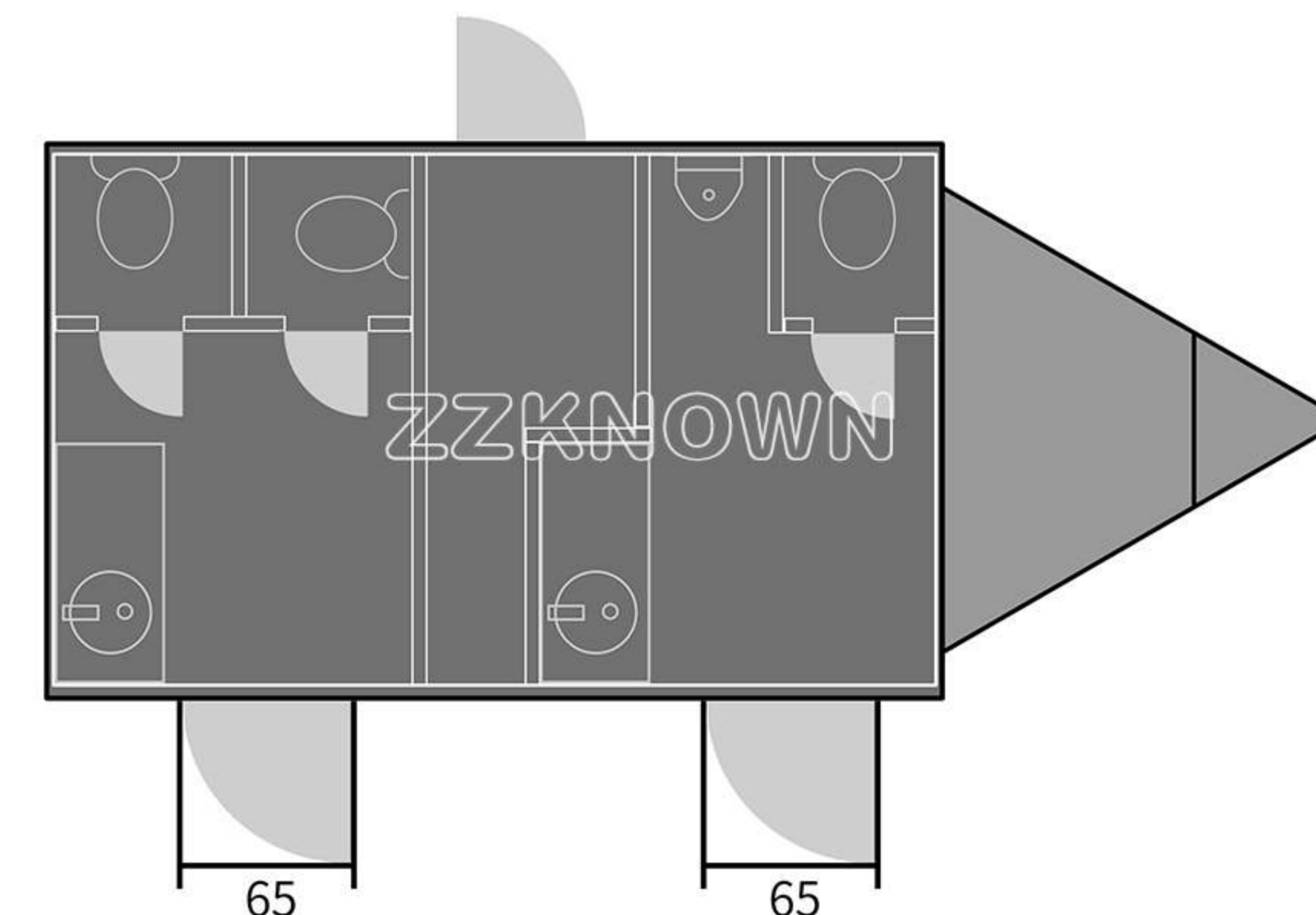

(No matter the length or the internal layout, it all can be customized!)

TOILET TRAILER



KN-500CS-1

Body Size (L*W*H)	5000*1700*2550mm (16.4'x5.58'x8.36' ft)
Weight(kg)	1400kg
Layout	3 Toilets + 1 Mechanical room
Package	40HQ container will fit in 2 units
MOQ	1 unit

Main Advantage:

1. Mobile public toilets have the advantages of being mobile, combined, and convenient for transportation.
2. Water saving: it saves 10 times as much water as the traditional flushing toilet, and the water consumption for each time is $\leq 0.5L$.
3. Energy saving: reduce sewage discharge, reduce the load of municipal sewage treatment plants by 80%, and save energy consumption.
4. Fresh air: when the excrement is sucked away, about 60 liters of air around the foreign body is sucked away, and the air is fresh and has no peculiar smell.
5. Stable performance: Adopt foreign imported accessories, and independently develop and integrate PLC control system, which is intelligent, stable, and simple to maintain.

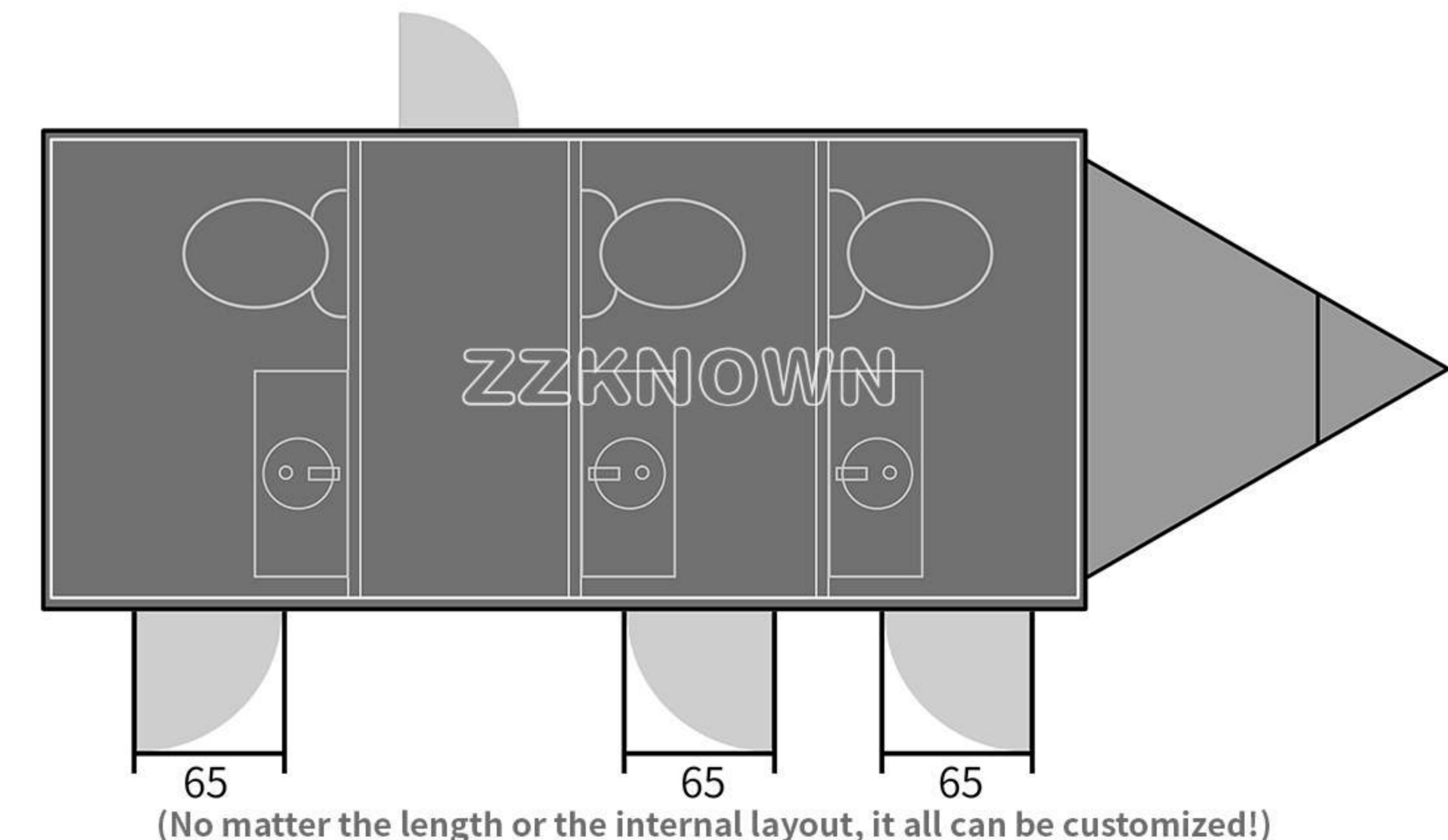

TOILET TRAILER



KN-500CS-2

Body Size (L*W*H)	5000*2100*2550mm (16.4'x6.89'x8.36' ft)
Weight(kg)	1400kg
Layout	3 Toilets & 1 urinal + 1 Mechanical room
Package	40HQ container will fit in 2 units
MOQ	1 unit

Main Advantage:

1. Mobile public toilets have the advantages of being mobile, combined, and convenient for transportation.
2. Water saving: it saves 10 times as much water as the traditional flushing toilet, and the water consumption for each time is $\leq 0.5L$.
3. Energy saving: reduce sewage discharge, reduce the load of municipal sewage treatment plants by 80%, and save energy consumption.
4. Fresh air: when the excrement is sucked away, about 60 liters of air around the foreign body is sucked away, and the air is fresh and has no peculiar smell.
5. Stable performance: Adopt foreign imported accessories, and independently develop and integrate PLC control system, which is intelligent, stable, and simple to maintain.

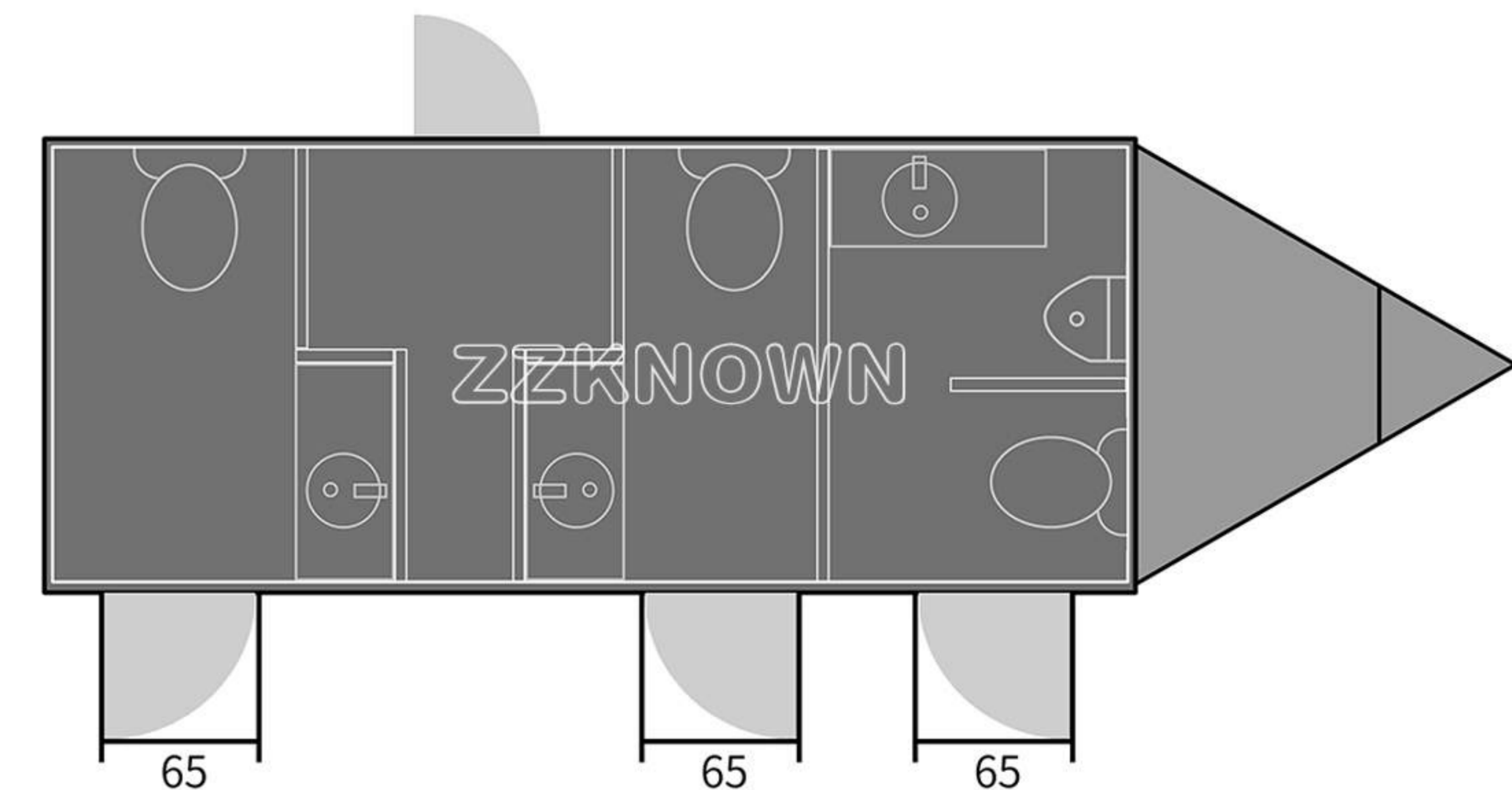

(No matter the length or the internal layout, it all can be customized!)

TOILET TRAILER



KN-280CS

Body Size (L*W*H)	2800*1700*2550mm (9.19'x5.58'x8.36' ft)
Weight(kg)	800kg
Layout	1Toilet + 1 Mechanical room
Package	40HQ container will fit in 4 units
MOQ	1 unit

Main Advantage:

1. Mobile public toilets have the advantages of being mobile, combined, and convenient for transportation.
2. Water saving: it saves 10 times as much water as the traditional flushing toilet, and the water consumption for each time is $\leq 0.5L$.
3. Energy saving: reduce sewage discharge, reduce the load of municipal sewage treatment plants by 80%, and save energy consumption.
4. Fresh air: when the excrement is sucked away, about 60 liters of air around the foreign body is sucked away, and the air is fresh and has no peculiar smell.
5. Stable performance: Adopt foreign imported accessories, and independently develop and integrate PLC control system, which is intelligent, stable, and simple to maintain.

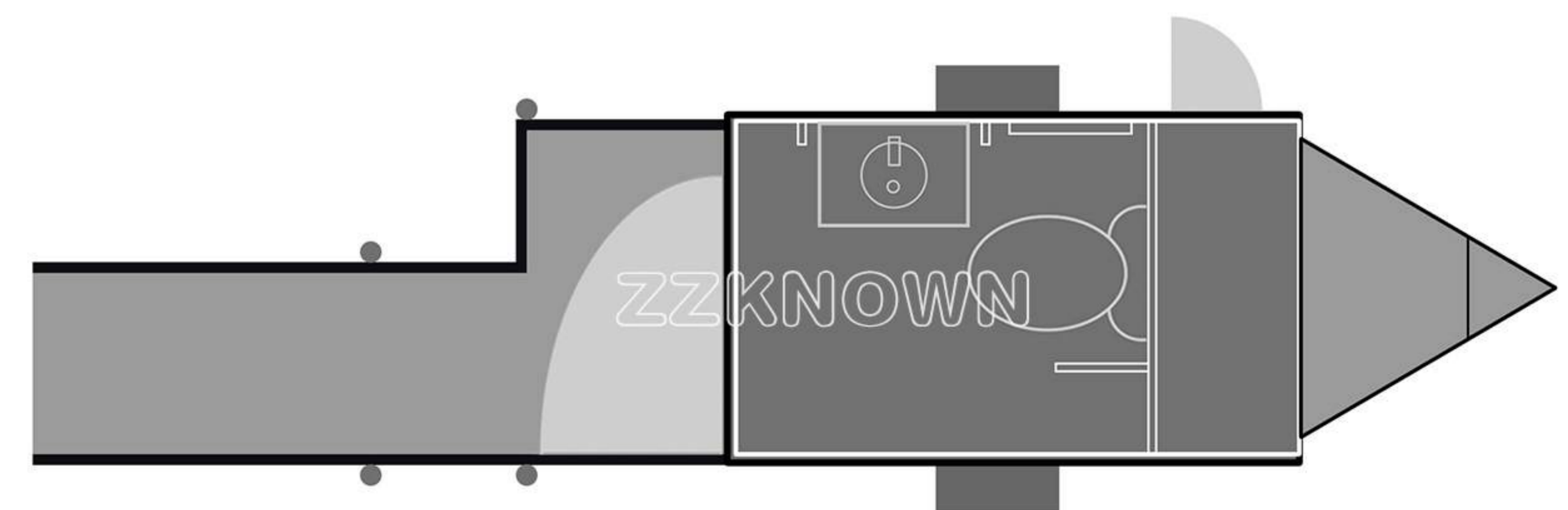

(No matter the length or the internal layout, it all can be customized!)

STANDARD CONFIGURATION

commercial toilet



mirriors

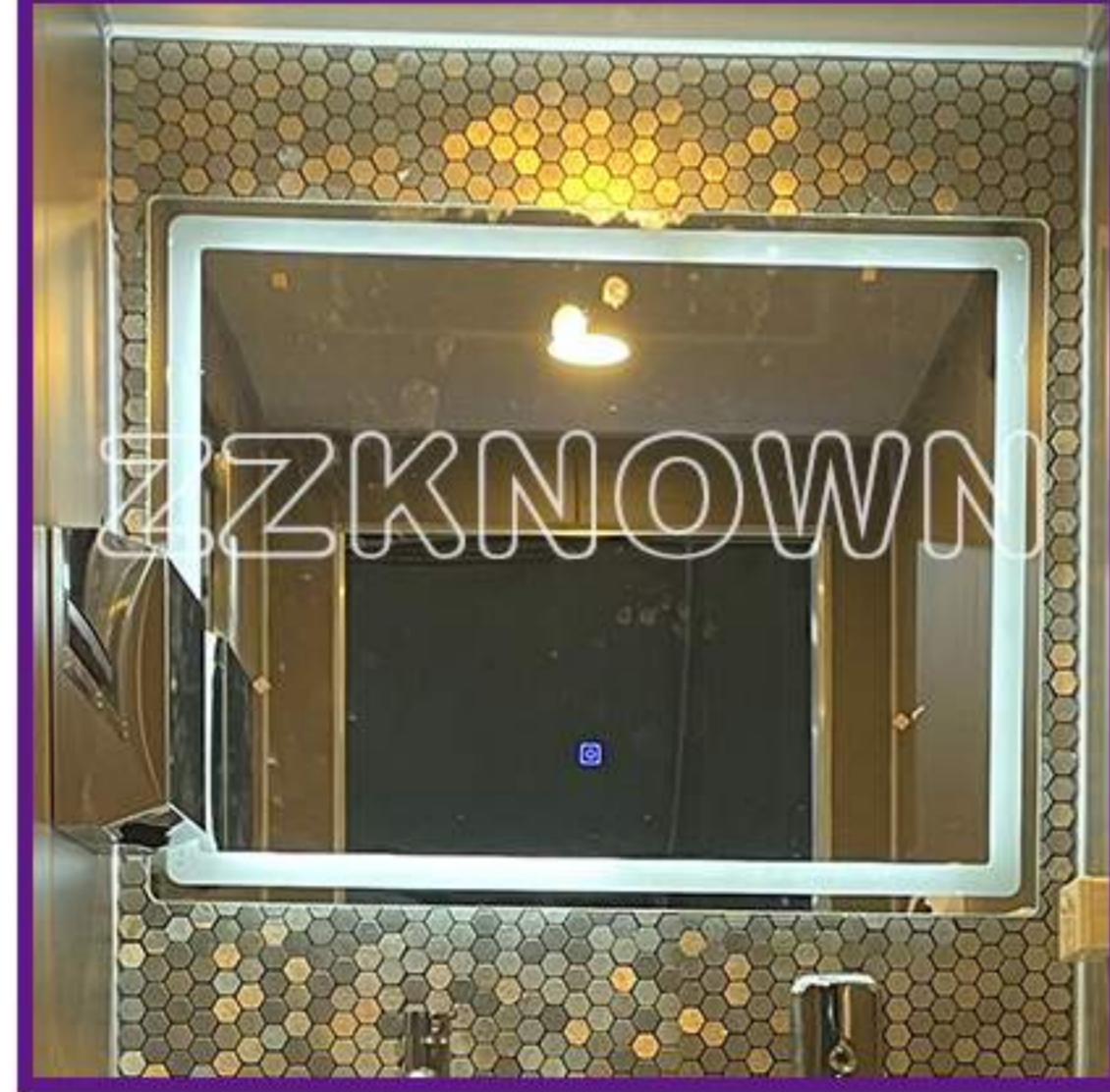

tissue box



strip light



speaker



hand sanitizer container



hook



exhaust fan



sign

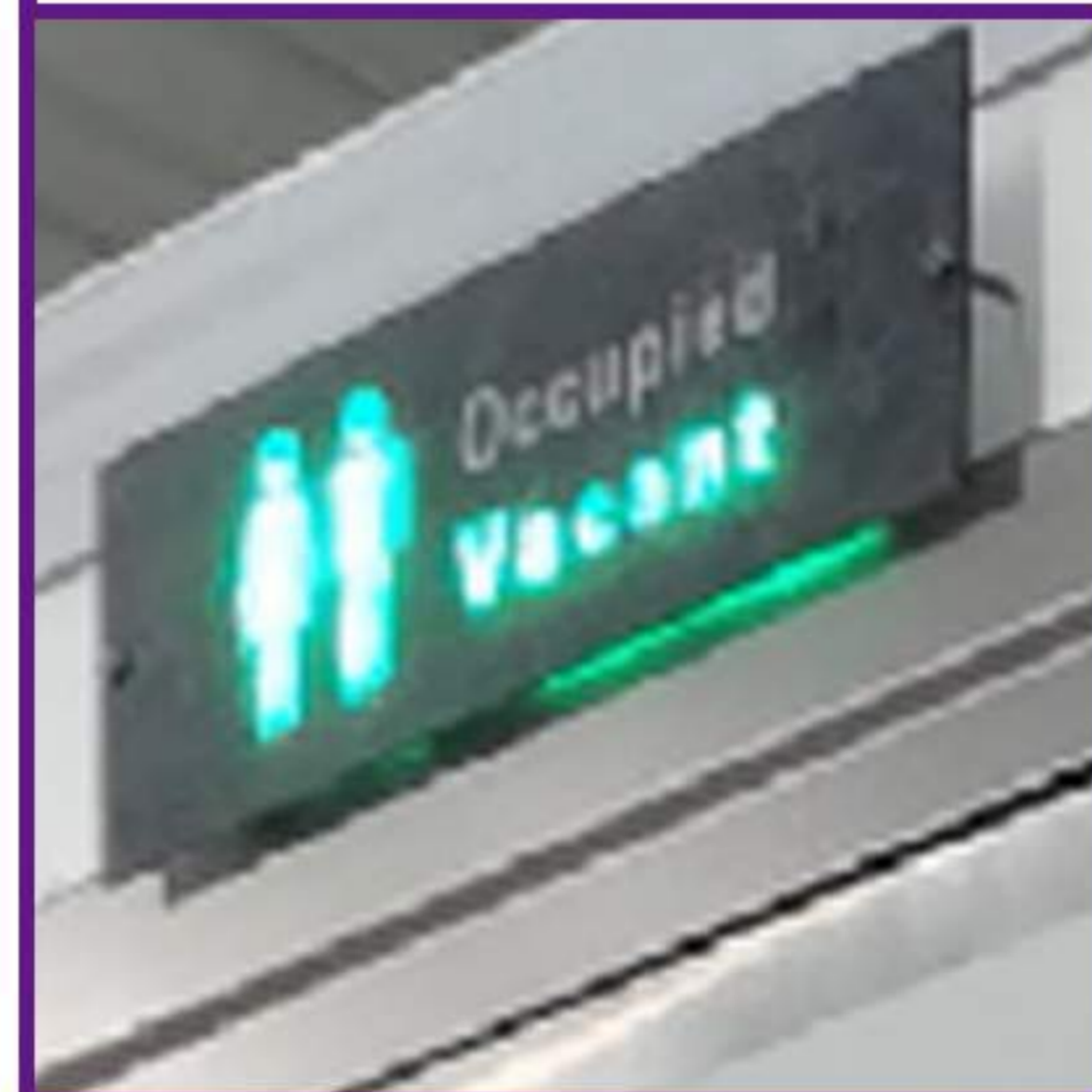

taillight



wheel



stair



fresh tank



sewage outlet



water inlet



handle



jack



external power plug



OPTIONS

Please choose if you need

Shower room configuration



Air conditioner



Solar panel



Water heater



Stainless steel wheels



Retractable staircase



Choose your favorite color, then tell me the color number!

ORDER PROCESS

Contact with us

01



Sign contract & Pay deposit

02



Design drawing + Production

03



Pay balance + Shipment

04



Arrival

05



Good review

06





LOADING AND SHIPMENT

